

Bending Beam - front view:

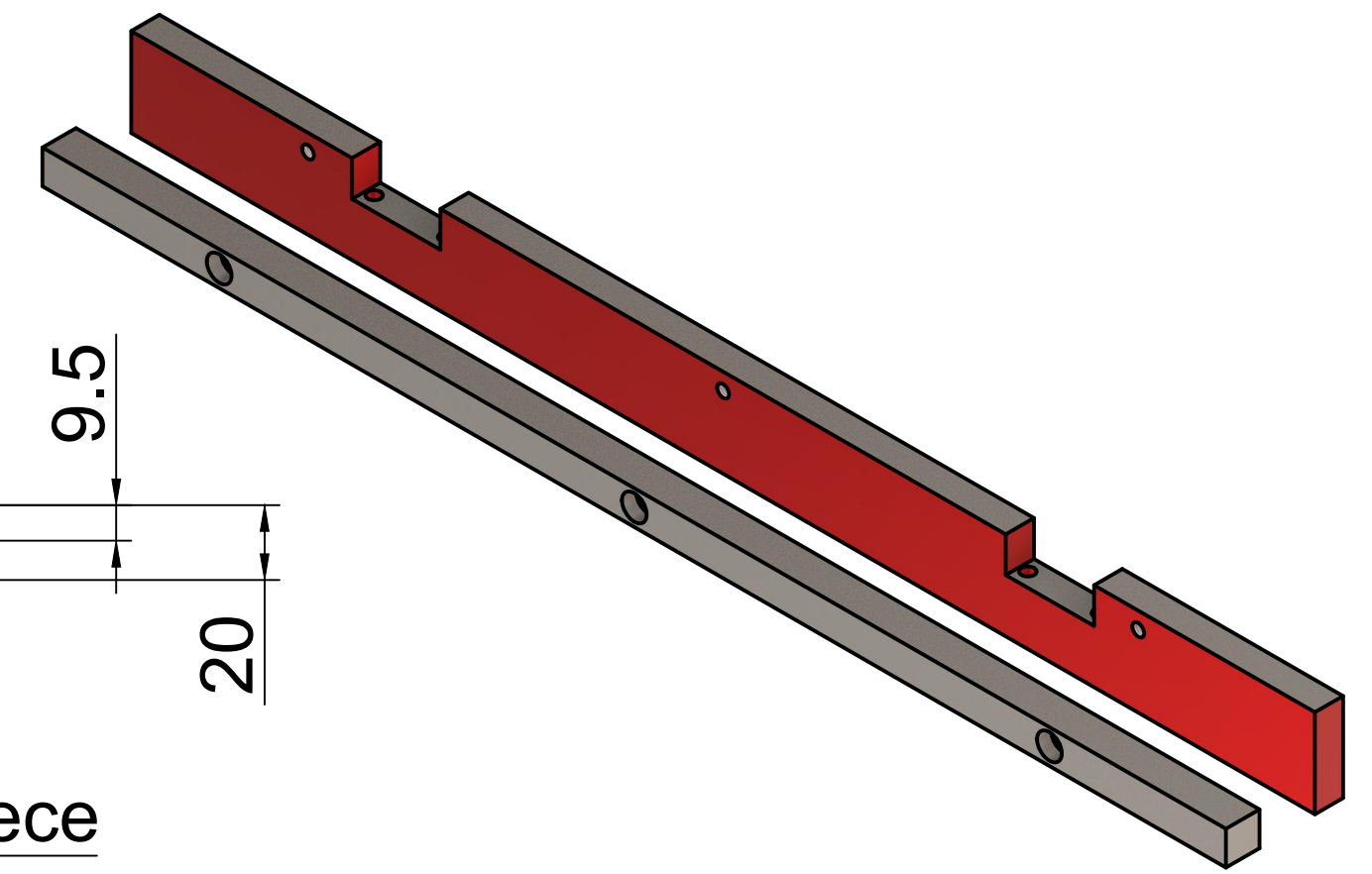

Bending Beam - top view:

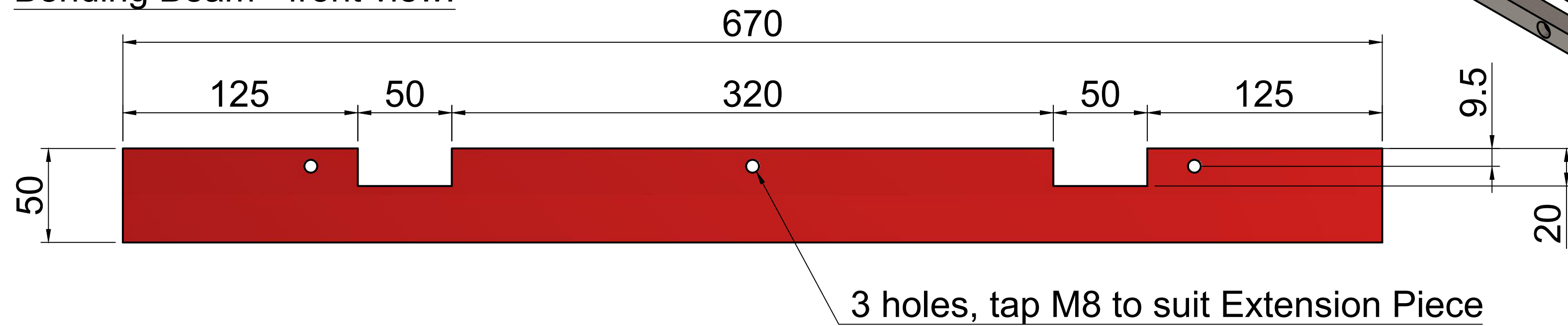
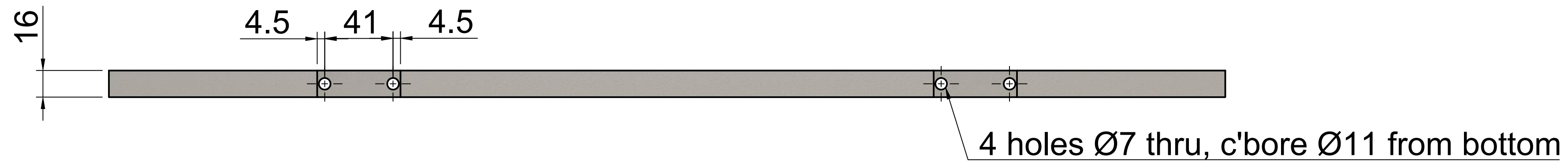

Bending Beam - bottom view:

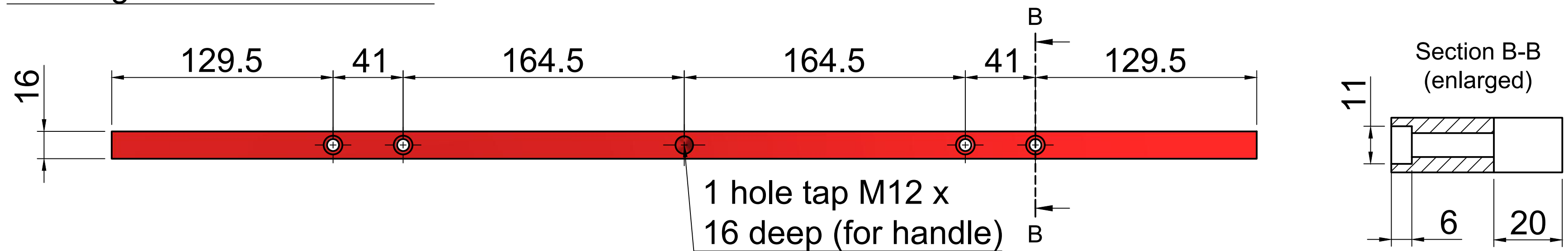

Extension Piece - front view:

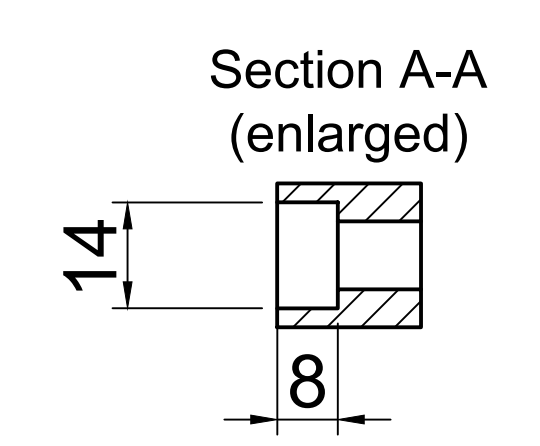
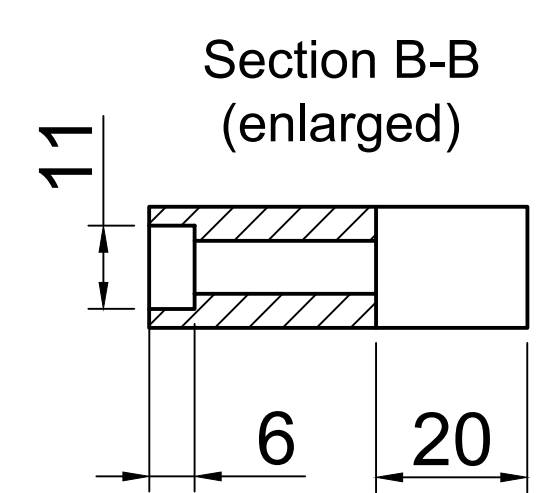
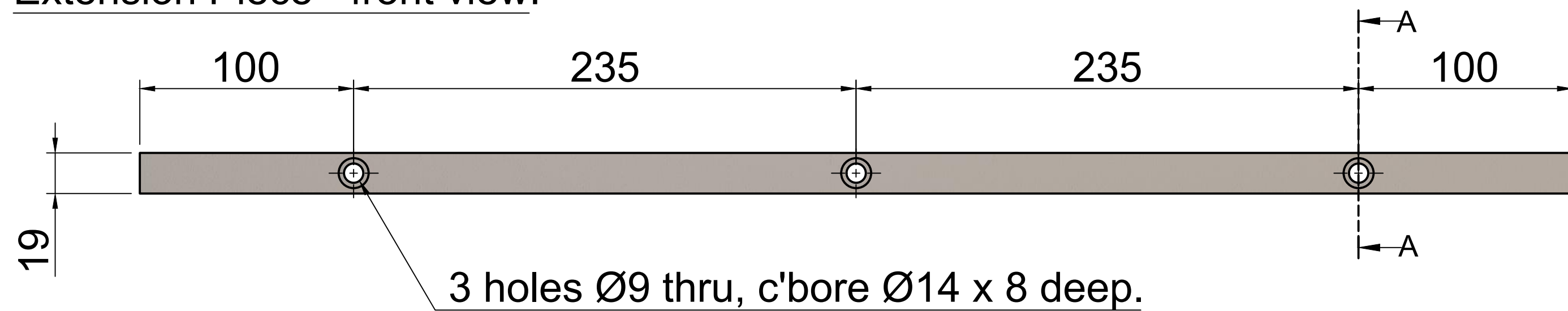

**BENDING BEAM & EXTENSION**  
Material: Bright Mild Steel (BMS)  
Design: A Bottomley, 7 July 2020